

**City of Keego Harbor  
Tax Increment Finance Authority  
(TIFA) Meeting Minutes  
Wednesday, April 1, at 4:00 pm**

**Call the Meeting to Order:**

Chairman Emerling called the meeting to order at 4:00 pm

**Roll Call:** Chairman David Emerling, Secretary Leslie Clark, Board Member Gino Santia, and Board Member Paul Daelemans.

*Motion by Secretary Clark; supported by Board Member Daelmans to excuse Board Member Drain.*

*Unanimous Vote: Ayes: 4                      Nays: 0*

*Motion Carries*

**Staff Present:**

City Manager / City Clerk Tammy Neeb, Deputy Clerk Stacy Goodall, and Treasurer Denise Hanley.

**Public Comment:**

Public comment was made.

**Approval of the Agenda:**

*Motion by Board Member Santia; supported by Board Member Daelemans to add two items to the agenda tonight.*

*Unanimous Vote    Ayes: 4                      Nays: 0*

*Motion carries*

**Approval of Meeting Minutes:**

*Motion by Secretary Clark; supported by Board Member Daelemans to accept the meeting minutes for Wednesday, March 4<sup>th</sup> TIFA meeting with the exception of the change regarding the flooded walkway.*

*Unanimous Vote:    Ayes: 4                      Nays: 0*

*Motion carries*

**Financial Report**

*Motion by Secretary Clark; supported by Board Member Santia to accept the revenue and expenditure report with a period ending March 31<sup>st</sup>.*

*Unanimous Vote: Ayes: 4*

*Nays: 0*

*Motion Carries*

**New Business:**

**Grant for Brock Street Canal Project**

City Manager Neeb has applied for a grant with a 20% match. TIFA may contribute to matching funds for the park side of the canal since it is in TIFA.

**2028 RCOC Cass Lake Road Project-Mckenna**

RCOC plans to asphalt Cass Lake Road curb-to-curb only. The project is not federally funded. TIFA would have to pay for the Michigan State Police to do a traffic study to lower the speed limit.

**Brock Street Canal Fountains**

*Resolution by Board Member Santia; supported by Board Member Daelemans for four floating fountain heads for Brock Street canal not to exceed \$900.*

*Roll Call: Clark yes, Santia yes, Daelemans yes, Emerling yes.*

*Resolution Carries*

**Old Business:**

**Fran Leaf Park- Flooded Walkway**

City Manager Neeb was not able to meet with HRC. Board members discussed obtaining specifications to move forward with getting three bids for this project.

**TIFA Marketing Support**

- **Developer Day** -City Council recommends moving this to September. Board members suggested September 9, 2026, from 10am-12pm.
- **Newsletter** -Board members would like to have a quarterly newsletter. They discussed the possible content. Sam Mariuz, from Fleis & Vandenbrink, will draft the newsletter for City Council.

**TIFA Projects**

- **Fran Leaf Park**
  - **Landscape/Approach-** Reopening the RFP will give a little more time for additional bids.

*Motion by Secretary Clark; supported by Board Member Daelemans ask City Manager to extend the due date for the bid to 2pm, Wednesday, April 8<sup>th</sup> at which time we will make a recommendation to council for them to review at the April council meeting.*

*Unanimous Vote: Ayes: 4 Nays: 0*

*Motion Carries*

- **Benches** -Penchura provided a quote for one 6-ft Dumor bench,

and one 22-gallon garbage can. Secretary Clark will send the information to Deputy Clerk Goodall to get quotes before either the next City Council meeting or TIFA meeting.

*Motion by Secretary Clark; supported by Chairman Emerling to request fresh quotes from three different bench suppliers including a garbage can in time for the next meeting, and when they come in, we will direct council with our choice.*

*Unanimous Vote:      Ayes: 4                      Nays: 0*

*Motion Carries*

- **Arch-** Clear specifications are needed to put out an RFP.
- **Kayak Launch-** Board members discussed the potential location for the kayak launch on Dollar Lake.

**Board Member Comments:**

The next meeting was scheduled for Wednesday, May 20, at 4:00 pm.

**Adjournment:**

Chairman Emerling adjourned the meeting at 5:54 pm.

---

David Emerling  
TIFA Board, Chairman

---

Stacy Goodall  
TIFA Board, Recording Secretary

GL NUMBER	DESCRIPTION	YTD BALANCE 04/30/2025	2025-26 AMENDED BUDGET	YTD BALANCE 04/30/2026	ACTIVITY FOR MONTH 04/30/26	AVAILABLE BALANCE	% BDGT USED
Fund 247 - TAX INCREMENT FINANCE AUTHOR FUND							
Revenues							
Dept 000 - UNCLASSIFIED							
247-000-402.000	CURRENT TAXES	330,374.75	337,700.00	326,227.41	5,483.89	11,472.59	96.60
247-000-573.000	LOCAL COMMUNITY STABILIZATION	2,457.92	2,500.00	0.00	0.00	2,500.00	0.00
Total Dept 000 - UNCLASSIFIED		332,832.67	340,200.00	326,227.41	5,483.89	13,972.59	95.89
TOTAL REVENUES		332,832.67	340,200.00	326,227.41	5,483.89	13,972.59	95.89
Expenditures							
Dept 000 - UNCLASSIFIED							
247-000-964.000	MISC EXPENSE	0.00	1,500.00	0.00	0.00	1,500.00	0.00
Total Dept 000 - UNCLASSIFIED		0.00	1,500.00	0.00	0.00	1,500.00	0.00
Dept 191 - ADMINISTRATION							
247-191-802.000	PROFESSIONAL AND TECHNICAL SER	83,803.88	50,000.00	11,749.07	1,522.03	38,250.93	23.50
Total Dept 191 - ADMINISTRATION		83,803.88	50,000.00	11,749.07	1,522.03	38,250.93	23.50
Dept 460 - ROUTINE STREET MAINTENANCE							
247-460-711.000	FICA	208.46	0.00	0.00	0.00	0.00	0.00
Total Dept 460 - ROUTINE STREET MAINTENANCE		208.46	0.00	0.00	0.00	0.00	0.00
Dept 693 - CASS LAKE ROAD							
247-693-702.000	WAGES-FULL TIME	2,725.00	32,500.00	33,134.26	1,209.16	(634.26)	101.95
247-693-711.000	FICA	0.00	3,060.00	2,534.30	92.50	525.70	82.82
247-693-711.004	HEALTH INSURANCE	0.00	10,000.00	6,626.78	0.00	3,373.22	66.27
247-693-711.005	RETIREMENT PLAN	0.00	2,600.00	1,015.40	0.00	1,584.60	39.05
247-693-711.006	LIFE INSURANCE	0.00	350.00	0.00	0.00	350.00	0.00
247-693-711.007	WORKERS COMP	0.00	400.00	0.00	0.00	400.00	0.00
247-693-812.000	ADMINISTRATION CHARGES	48,195.00	50,408.00	50,408.00	0.00	0.00	100.00
247-693-830.005	FACADE IMPROVEMENTS - PROGRAM	0.00	50,000.00	0.00	0.00	50,000.00	0.00
247-693-944.000	RENTAL OF EQUIPMENT	4,835.17	12,000.00	9,989.92	1,009.45	2,010.08	83.25
247-693-970.000	CAPITAL EXPENSES	37,609.61	150,000.00	14,901.62	0.00	135,098.38	9.93
Total Dept 693 - CASS LAKE ROAD		93,364.78	311,318.00	118,610.28	2,311.11	192,707.72	38.10
Dept 899 - TAX TRIBUNAL/OTHER REFUNDS ORDERED							
247-899-956.000	COSTS, FEES, AND CHARGES	347.40	700.00	226.66	53.80	473.34	32.38
Total Dept 899 - TAX TRIBUNAL/OTHER REFUNDS ORDERED		347.40	700.00	226.66	53.80	473.34	32.38
Dept 965 - APPROPRIATED TRANSFERS OUT							
247-965-999.353	TRANSFER OUT TO TIFA 2013 DEBT	71,608.45	0.00	0.00	0.00	0.00	0.00
Total Dept 965 - APPROPRIATED TRANSFERS OUT		71,608.45	0.00	0.00	0.00	0.00	0.00

GL NUMBER	DESCRIPTION	YTD BALANCE		2025-26		YTD BALANCE	ACTIVITY FOR	AVAILABLE	% BDDT	
		04/30/2025	AMENDED BUDGET	04/30/2026	MONTH					BALANCE
Fund 247 - TAX INCREMENT FINANCE AUTHOR FUND										
Expenditures										
TOTAL EXPENDITURES		249,332.97	363,518.00	130,586.01	3,886.94	232,931.99			35.92	
Fund 247 - TAX INCREMENT FINANCE AUTHOR FUND:										
TOTAL REVENUES		332,832.67	340,200.00	326,227.41	5,483.89	13,972.59			95.89	
TOTAL EXPENDITURES		249,332.97	363,518.00	130,586.01	3,886.94	232,931.99			35.92	
NET OF REVENUES & EXPENDITURES		83,499.70	(23,318.00)	195,641.40	1,596.95	(218,959.40)			839.01	



---

**To: TIFA**

**Date: May 20, 2026**

**Subject: Oakland County Main Street Introductory Board Training**

---

**BACKGROUND:**

Annaka Norris

**RECOMMENDATION:**

Discussion



---

**To: TIFA**  
**Date: May 20, 2026**  
**Subject: City Owned Property in TIFA District**

---

**BACKGROUND:**

**RECOMMENDATION:**

Discussion

# Tax Increment Finance Authority District

City of Keego Harbor, Michigan

DRAFT February 5, 2026

## LEGEND

-  Keego Harbor
-  TIFA Boundary
-  Development Area
-  Added to the Development Area in the 2025 TIF and Development Plan Update

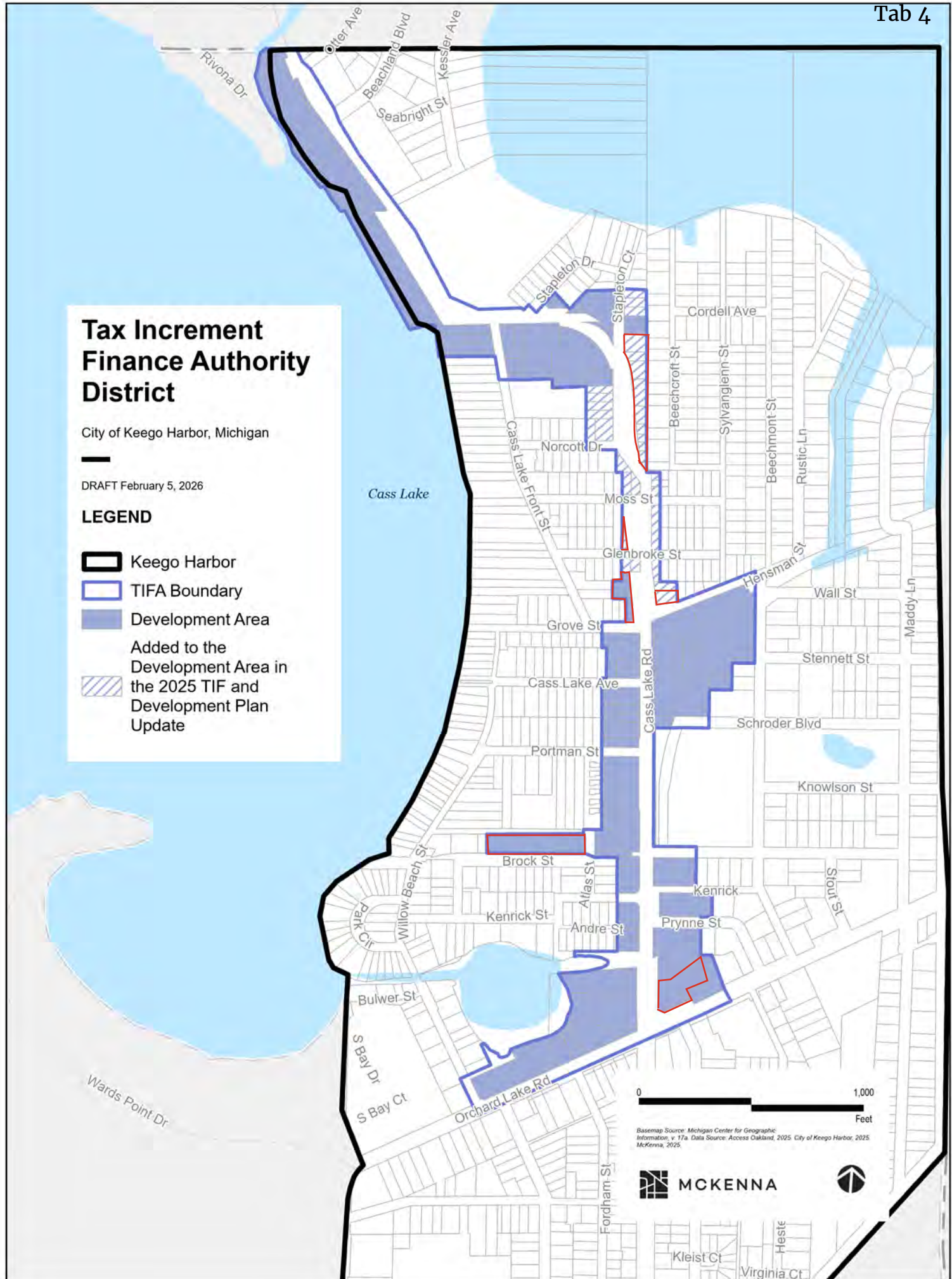

Basemap Source: Michigan Center for Geographic Information, v. 17a. Data Source: Aconex Oakland, 2025. City of Keego Harbor, 2025. McKenna, 2025.

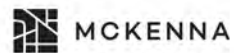



---

**To: TIFA**

**Date: May 20, 2026**

**Subject: Fran Leaf -Flooded Walkway**

---

**BACKGROUND:**

**RECOMMENDATION:**

Discussion

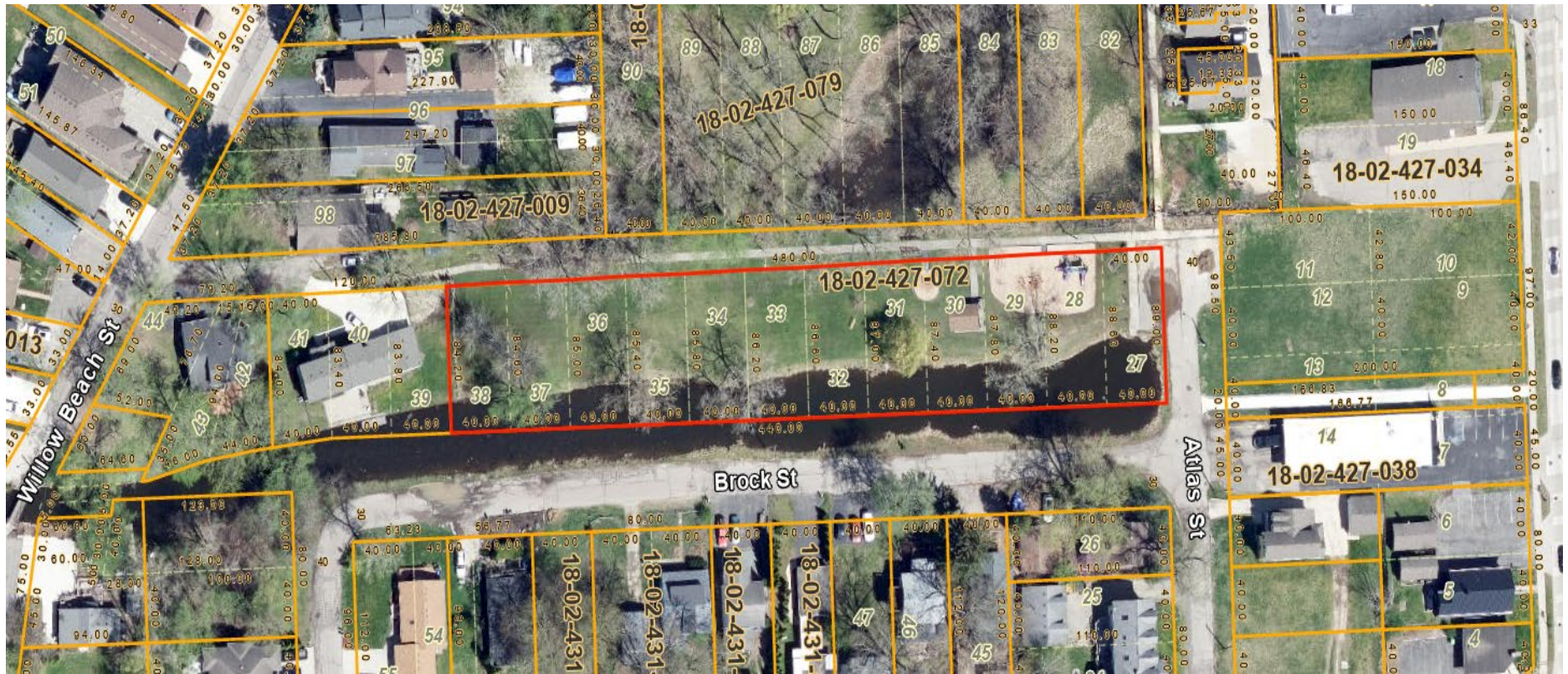

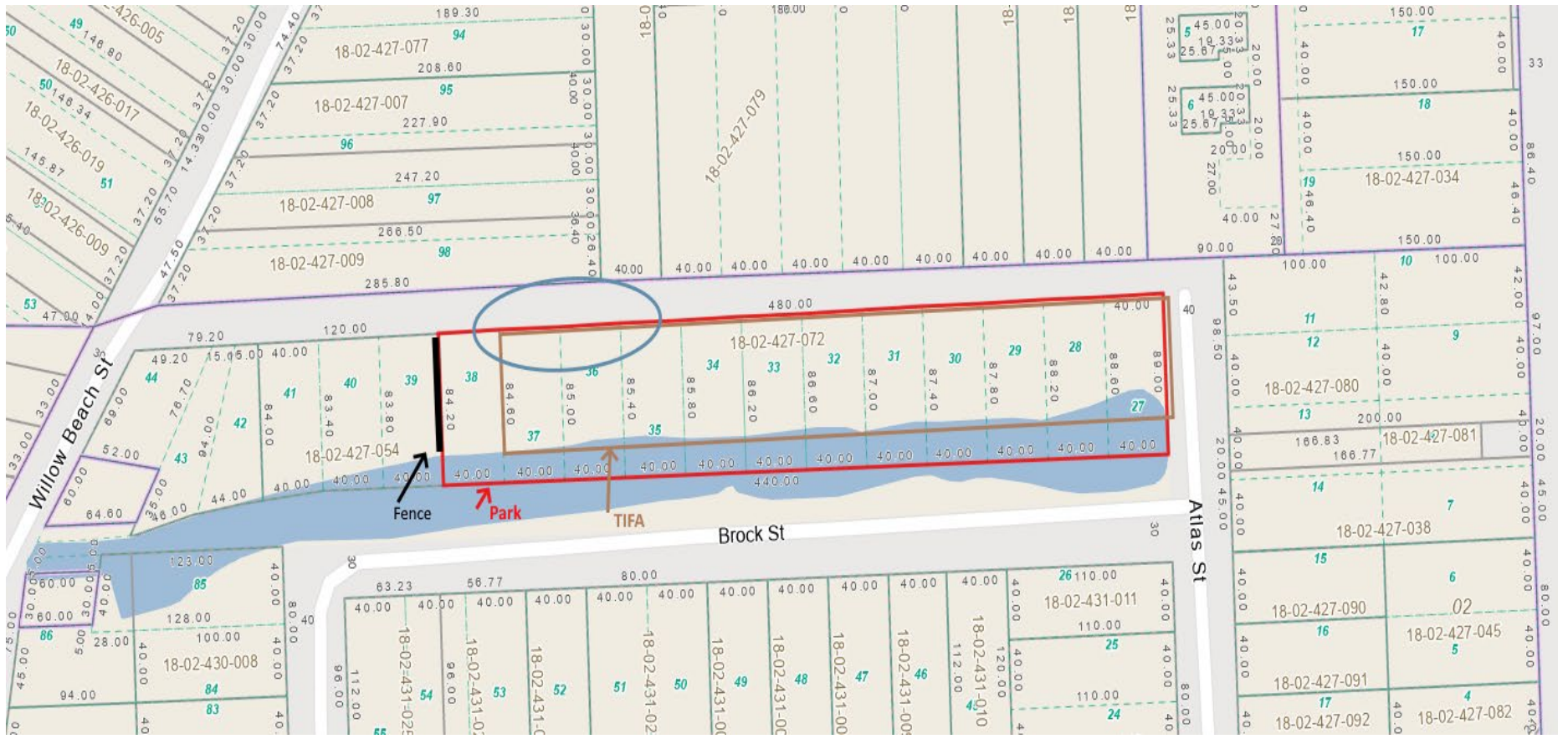



---

**To: TIFA**

**Date: May 20, 2026**

**Subject: TIFA Marketing Support**

---

**BACKGROUND:**

TIFA Newsletter

**RECOMMENDATION:**

Discussion

# KEEGO HARBOR

## TAX INCREMENT FINANCE AUTHORITY

COMING SOON:

### DEVELOPER DAY

Keego Harbor is preparing to host a Developer Day to showcase opportunities for investment and redevelopment within the TIFA district.

Planned as a guided, on-the-ground experience, Developer Day will highlight key sites, recent improvements, and the tools available to support new development along the corridor. This effort is part of the City's broader focus on attracting thoughtful, high-quality investment that aligns with community goals.

More details coming soon!

### GRANT OPPORTUNITY

The Keego Harbor TIFA Façade Improvement Grant Program provides funding to help property and business owners improve storefronts, signage, and building exteriors. This is a great opportunity to enhance your space, attract more customers, and elevate your presence along the corridor. Join other local businesses in investing in Keego Harbor and help create a more vibrant and welcoming community.

[CLICK HERE TO APPLY TODAY](#)



## FUELING LOCAL PROGRESS: INSIDE KEEGO HARBOR'S TIFA



The Keego Harbor Tax Increment Finance Authority (TIFA), established under Michigan's Public Act 57 of 2018, is a local economic development tool designed to reinvest growth back into the community. As property values increase within the TIFA district, a portion of the new tax revenue is captured and directed toward public improvements such as streetscapes, infrastructure upgrades, façade enhancements, and business support programs. This allows Keego Harbor to strengthen its commercial corridor, attract private investment, and enhance the overall quality of place, ensuring long-term economic vitality for residents and businesses alike.

[keegoharbor.org](http://keegoharbor.org)



---

**To: TIFA**

**Date: May 20, 2026**

**Subject: TIFA Projects**

---

**BACKGROUND:**

Fran Leaf Park :

- Landscaping RFP- The City has received only one response to our bid request despite repeated direct outreach to multiple local, responsible landscapers. At this point, staff believes it may be necessary to proceed with the one qualified company that expressed interest in completing the work. The following companies were contacted:
  1. Golder Walsh Garden and Home – No response
  2. Aquafina Gardens International – No response
  3. Creative Brick Paving & Landscaping (Creative Design Build Associates) – Bid received in the amount of \$21,908.00
  4. Schecter Landscaping Inc. – No response
  5. Auburn Oaks Garden Center – No response
  6. Bloomfield Land and Plants – No response
  7. English Gardens Landscape Division – No response

TIFA intends to ratify the expense contingent upon Council approval to proceed with Creative Brick Paving & Landscaping. TIFA will ratify the expense if council approval to move forward with Creative Brick Paving and Landscaping.

- Bench Quotes
  - Barco
  - Belson
  - Penchura
- Arch RFP
  - Stefani
  - Metal City

**RECOMMENDATION:**

Discussion

Resolution to Ratify the Creative Brick Paving & Landscaping bid in the amount of \$21,908.00.

Resolution to recommend the purchase of park benches for Fran Leaf Park from \_\_\_\_\_, not to exceed \$\$\$.

# CREATIVE DESIGN & BUILD

3195 Orchard Lake Road Keego Harbor, MI 48320 248.631.4151  
Landscape/Hardscape Enhancement Proposal

Client Name: City of Keego Harbor - TIFA Sidewalk Landscape  
Project Address: (Parcel 18-02-427-081) Keego Harbor, Michigan 4 8 3 2 0  
Phone Number: 248.682.1930 Email:

3/24/2026

Quantity	Item	Unit Price	Total Price
<b>Hardscape + Site Prep</b>			
30	Clear and prep landscape beds per new layout (natural bed edging)		
4	Prep area for hardscape		
48	Square feet supply and install endura color pavers (pedestrian)		
20	Lineal feet edge restraint		
48	Polymeric jointing sand (hardener) Grey & Tan (Small Joints)		
4	Delivery and Hauling of Material and Debris		
1	Disposal Fee		
	<b>Subtotal</b>		<b>\$ 5,318.00</b>
<b>Planting Material (Installed)</b>			
9	Grass, Switch 'Heavy Metal' (Panicum virgatum) 1 gal		
10	Sedge, White-tinged (Carex albidans) 1 gal		
7	Sedge, Fox (Carex vulpinoides) 2.5" pot or plug		
10	Amsonia Blue Ice (Amsonia x 'Blue Ice') 1 gal		
43	Canada Anemone (Anemone canadensis) 2.5" pot or plug		
4	Aster, New England 9Symphyotrichum novae-angliae) 1 gal		
4	Cardinal Flower (Lobelia cardinalis 'Queen Victoria') 1 gal		
12	Hibiscus, Pink (Hibiscus moscheutos) 1 gal		
6	Iris, Southern Blue Flag (Iris versicolor) 2.5" pot or plug		
21	Honeysuckle, 'Kodiak Orange' 9Diervilla rivularis x 'Kodiak Orange') 5gal		
4	Lilac 'Boomerang' Dark Purple (Syringa x 'SMSJBP7') 3 gal		
2	Dogwood, Dwarf Redtwigged Kelsey's (Cornus sericea 'Kelseyi') 3 gal		
11	Juniper, Arcadia (Juniperus sabina 'Arcadia') 3 gal		
21	Juniper, Blue Chip (Junierus horizontalis 'Blue Chip') 3 gal		
4	Black Tupelo - Firestarter (Nyssa sylvatica 'Firestarter') 2" cal B&B		
17	Yards of Shredded Cedar Mulch 2" depth		
3	Cubic yards of 5-10" Field Stone over fabric		
1.5	Cubic yards of 1-2" Stone over fabric (small gaps)		
15	Screen Topsoil - 50/50 plant mix blend		
1	Minor Lawn Restoration (seed and straw blanket)		
	<b>Subtotal</b>		<b>\$ 16,590.00</b>
<b>Notes:</b>			
* 1 Year warranty From time of completion			
When plants are available we schedule the work with the city. The work will take 2-3 days to complete from staging to final clean up.			
Plant material cost is based on current pricing and availability (exact or similar item)			
		<b>Total Sheet 1</b>	<b>\$ 21,908.00</b>
		<b>Permit Fees</b>	<b>NA</b>
		<b>Total For Project</b>	<b>\$ 21,908.00</b>

## Clerk

---

**From:** Stephen Creativebp <stephen@creativebp.com>  
**Sent:** Tuesday, March 24, 2026 12:17 PM  
**To:** manager; Stacy Goodall  
**Cc:** info creativebrickpaving.com  
**Subject:** Landscaping Services for TIFA Walkway - (Creative)  
**Attachments:** Keego Harbor TIFA Walkway Landscape Estimate\_3.24.26.pdf

Good afternoon,

Please find the attached estimate for the TIFA walkway landscape installation project.

This proposal includes a one-year warranty, and the project is expected to take approximately 2–3 days to complete, from staging through final cleanup.

If you have any questions or need further details, please feel free to call or email at your convenience.

Thank you,



**Stephen Bonamy**

3195 Orchard Lake Rd, Keego Harbor, MI 48320

**O:** 248.631.4151      **C:** 248.320.5626

**Email:** [stephen@creativebp.com](mailto:stephen@creativebp.com)

**Website:** <http://www.creativebp.com>



---

**Barco Products: Quote# QUORCO34265**

---

From Barco Products <keyaccounts@barcoproducts.com>

Date Tue 4/7/2026 3:14 PM

To Stacy Goodall <Goodall@keegoharbor.org>

Dear Stacy Goodall:

Thank you for your interest in Barco Products. Below is the quote you have requested. Kindly review the details for accuracy and let us know if any changes are necessary or when you are ready to proceed with the order. **Please note that the product pricing is valid for 30 days and, due to current market uncertainties, cannot be extended beyond that period.**

We look forward to doing business with you.

Thank you,

Tabitha  
Barco Products Sales Representative  
(630) 845-5469

**P.S.** KirbyBuilt and TreeTop Products are officially united under one name: **Barco Products**. This means one trusted source for all your commercial site furnishing needs. You will see additional names and SKU numbers on select products to help customers during this transition. Barco Products will appear on your billing statement and order confirmation. If you have any questions, we're here to help:

**USA:** (800) 338-2697

**Canada:** (866) 538-5848

Please review our company's **Product Warranty, Shipping Policy, and Return Policy** as stated at the bottom of our website: [www.barcoproducts.com](http://www.barcoproducts.com) before placing your order.



# Quote

Account Number - 395372

Barco Products, LLC  
24 N Washington Ave  
Batavia IL 60510  
(800) 338-2697  
customerservice@barcoproducts.com

## Estimate # QUORCO34265

4/7/2026

Customer

Ship To

Tammy Neeb  
City of Keego Harbor  
2025 Beechmont Street  
Keego Harbor MI 48320  
(248) 515-2978

City of Keego Harbor  
2010 Maddy Lane  
Keego Harbor MI 48320

Barco SKU	Qty	Rate	Amount	Estimated Lead Time
<b>02CL1300-BK</b> Cassidy Straight Back Bench/ 6' Bench/ Black	1	\$1,145.00	\$1,145.00	Ships in 1 to 2 Days
<b>08CL1420-BK</b> Cassidy™ Receptacle/ 32 Gal Flat Lid Receptacle/ Black Onyx	1	\$1,055.00	\$1,055.00	Ships in 1 to 2 Days

---

<b>Subtotal</b>	\$2,200.00
<b>Tax Total (%)</b>	\$0.00
<b>Shipping</b>	\$293.04
<b>Total</b>	\$2,493.04

\*Estimated lead time is based on normal fulfillment time of an order at this moment. Orders with large quantities may require additional time. These estimates are subject to change based on the nationwide supply chain issue.

**PRICING FOR THIS QUOTE IS LOCKED IN FOR 30 DAYS**

**Quote #**  
**WQ 394900**

Here is the Quote as per your request. The 'Shipping' total has been applied.  
To place an order, simply click 'Submit Order Confirmation' below.  
Please print this page for your records.  
Customer Order Confirmation is **required** to process order.



627 Amersale Drive  
Naperville, IL. 60563  
sales@belson.com

Toll Free: 1-800-323-5664  
Phone: 1-630-897-8489  
Fax: 1-630-897-0573

**QUOTE #**  
**WQ 394900**

**Expires 4/22/2026**

Model #	Description	Lbs	Quantity	Unit Price	Unit Total
P922-S6	6' Savannah Bench, Powder-Coated, Slat Powder-Coated   Matte Black *Discount Applied*	240	1	\$2,350.00	\$2,350.00
PSV-S32FT	32 Gallon Savannah Slat Receptacle With Flat Top Lid & Plastic Liner, Powder-Coated Powder-Coated   Matte Black *Discount Applied*	160	1	\$2,050.00	\$2,050.00

Subtotal	400	Subtotal	\$4,400.00
		0.0000% Tax	\$0.00
		Freight - S&H	\$598.33
		Grand Total	\$4,998.33

Customer Order Confirmation is required to process order.

Your Order will not be shipped without your "Order Confirmation"

**Bill To:**

**Ship To:**

<b>First/Last Name</b> Stacy Goodall	
<b>Company</b> City of Keego Harbor	<b>Ship To</b> Keego Harbor DPW
<b>Address 1</b> 2010 Maddy Ln	<b>Address 1</b> 2010 Maddy Ln
<b>Address 2</b>	<b>Address 2</b>
<b>City</b> Keego Harbor	<b>City</b> Keego Harbor
<b>State</b> MI	<b>State</b> MI
<b>Zip Code</b> 48320	<b>Zip Code</b> 48320
<b>Country</b> USA	<b>Country</b> USA
<b>Phone</b> 248-682-1930	<b>Phone</b> 248-682-1930 x5
<b>Fax</b>	<b>Contact</b> Stacy Goodall
<b>Email</b> goodall@keegoharbor.org	<b>Email</b> goodall@keegoharbor.org

**Additional Delivery Services**

Phone Call 24 Hours Prior to Delivery◊
Delivery to Residential or Non-Commercial Truck Route Addresses
Power Liftgate Service◊ - Driver will lower shipment from the truck to the ground (Only)
<b>Order Power Liftgate Service if — You</b> will be unable to unload the shipment from the truck.
◊ <b>Does Not apply to UPS shipments</b>

**Special Instructions**



Make all P.O.s, Contracts, and Checks to:  
**Penchura, L.L.C.**  
 889 S. Old US 23  
 Brighton, MI 48114

# Proposal

Date	Project #
4/10/2026	26-426

<b>Bill To</b>
City of Keego Harbor Ms. Linda Voll, clerk@keegoharbor.org 2025 Beechmont St. Keego Harbor, MI 48320

<b>Ship To</b>
Keego Harbor Dept. of Public Works 2010 Maddy Lane Keego Harbor, MI 48320

<b>Customer Contact</b>	<b>Customer Phone</b>	<b>Customer Fax</b>	<b>Terms</b>	<b>P.O. No.</b>	<b>Rep</b>
Linda Voll	248-682-1930 ext 4		Net 30		SH

Item	Description	Qty	Weight	Price	Total
58-60	DuMor 6' Cast Bench with Steel Seat, Black	1		1,680.00	1,680.00
102-22SH-FTO	DuMor 22 Gal Steel Receptacle, w/Shield, Flat Cover, Black	1		1,970.00	1,970.00
Freight	Freight with Lift Gate	1		471.00	471.00
Lead Time	8-12 weeks				
**	Please make any necessary changes to the shipping or billing address. Thank you.				
Deliveries	At time of delivery check for missing or damaged packages, note these issues on the bill of lading prior to signing it, and tell the driver prior to his or her leaving your site. Contact Penchura as soon as possible.				
Items Pricing	Price does not include assembly, installation, lift gates, or residential deliveries, unless noted. Pricing available upon request.				

Proposal good for 30 days.  
 Ship Via: common carrier  
 Delivery contact name and number: \_\_\_\_\_

Customer signature below constitutes a purchase order.

\_\_\_\_\_

<b>Subtotal</b>	\$4,121.00
<b>Sales Tax (0.0%)</b>	\$0.00
<b>Total</b>	\$4,121.00

**Credit Card fee of 3% on all payments using a CC.**  
**AMX fee of 5% on all payments using AMX**

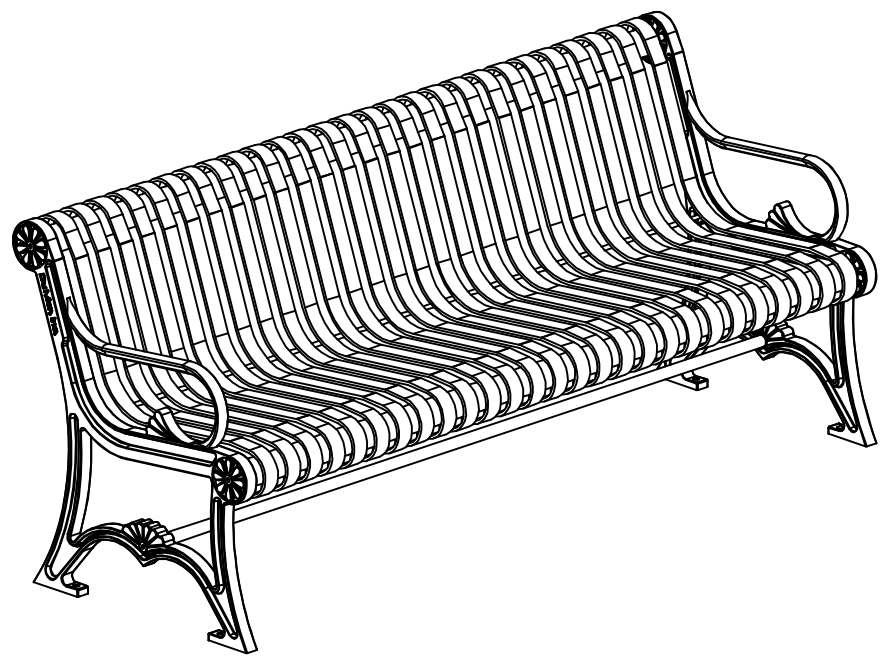
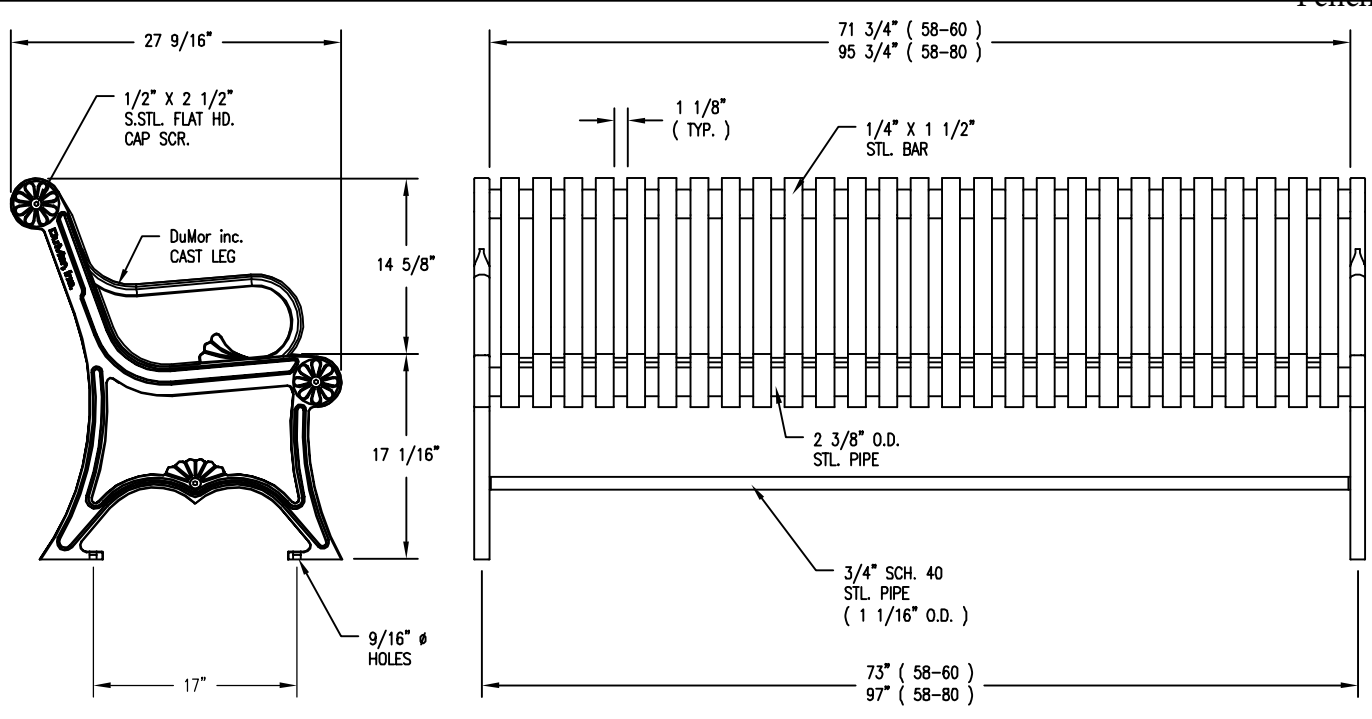

**NOTES**

- 1.) ALL STL. MEMBERS COATED W/ ZINC RICH EPOXY THEN FINISHED W/ POLYESTER POWDER COATING.
- 2.) 1/2" X 3 3/4" EXPANSION ANCHOR BOLTS PROVIDED.
- 3.) CUSTOM LETTERING AVAILABLE FOR RECESSED SIDE PANELS ( TOTAL OF 37 SPACES )

CUSTOM LETTERING ( 37 SPACES )

**LENGTH OPTIONS**

- 6' BENCH
- 8' BENCH

**NOTES:**

- 1.) DURING ASSEMBLY PROCEDURE; DO NOT COMPLETELY TIGHTEN HARDWARE.
- 2.) THE ACTUAL PARTS WILL NOT BE NUMBERED. NUMBERS ONLY APPLY TO DRAWING.
- 3.) UPON COMPLETION OF ASSEMBLY SQUARE ALL COMPONENTS THEN TIGHTEN ALL HARDWARE.
- 4.) MOUNT AND ANCHOR AS SPECIFIED.

**TOOLS REQ'D**

- 3/4" WRENCH
- 5/16" ALLEN WRENCH
- 1/2" MASONRY DRILL BIT
- DRILL
- RATCHET STRAP (PROVIDED)

**PARTS LIST**

ITEM	QTY	PART NO	DESCRIPTION
1	2	0-57-00-02	CAST IRON BENCH SUPPORT W/BACK
2	1	0-57-60-04	71 3/4" PIPE BRACE
3	1	0-58-60-01	6' STL SEAT
4	6	1-12-065	1/2" X 2 1/2" FLT SKT HD CAP SCR

**KITS PROVIDED**

ITEM	QTY	PART NO	DESCRIPTION
5	1	K-FC0840-6	1/2" CAP HARDWARE KIT (6PC)
6	1	K-ANC0860-4	1/2" X 3 3/4" SS ANCHOR KIT (4PC)

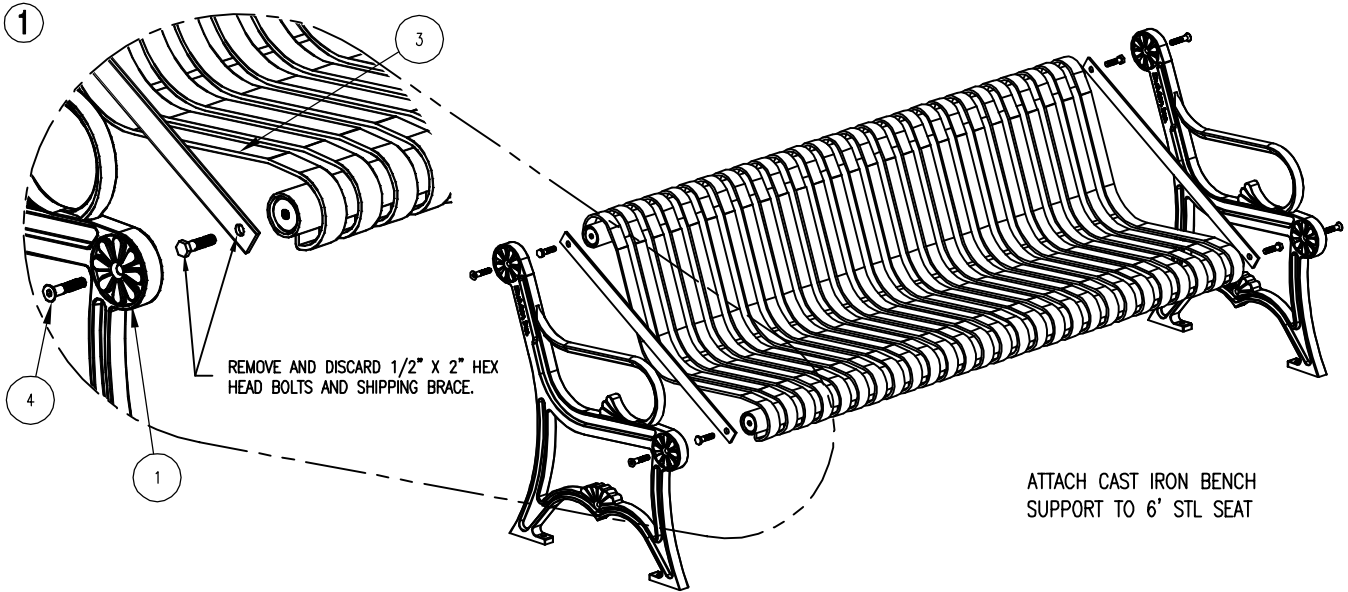

ATTACH CAST IRON BENCH SUPPORT TO 6' STL SEAT



PLACE SEAT ASSEMBLY ON WORK SURFACE ALLOWING ACCESS TO ENDS. PLACE RATCHET STRAP AROUND SEAT ASSEMBLY AS SHOWN ABOVE.



TIGHTEN STRAP UNTIL SHIPPING BRACKET BECOMES LOOSE. THEN REMOVE AND DISCARD BOLTS & SHIPPING BRACKET.



ATTACH CAST SUPPORT TO SEAT ASSEMBLY. IF HOLES IN CASTING DO NOT ALIGN WITH THE SEAT ASSEMBLY, ADJUST BY USING THE RATCHET STRAP.



TIGHTEN HARDWARE THEN REMOVE RATCHET STRAP AND REPEAT THIS PROCEDURE ON THE OTHER END OF BENCH.

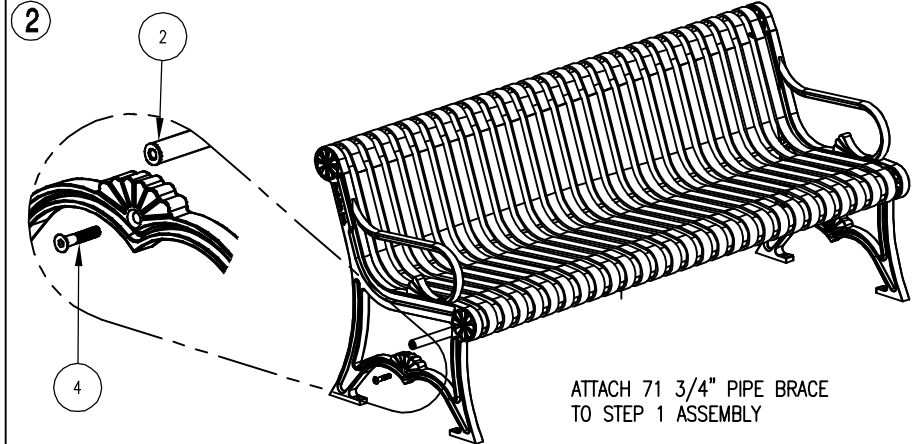

ATTACH 71 3/4" PIPE BRACE TO STEP 1 ASSEMBLY



**ASSEMBLY INSTRUCTIONS**

DATE DRAWN : 3/22/94  
 DRAWN BY : AH  
 DATE REV. : 11/21/99  
 REV. BY : JSB

REV. D

DRAWING NUMBER

58 SERIES

SHEET 2 OF 2

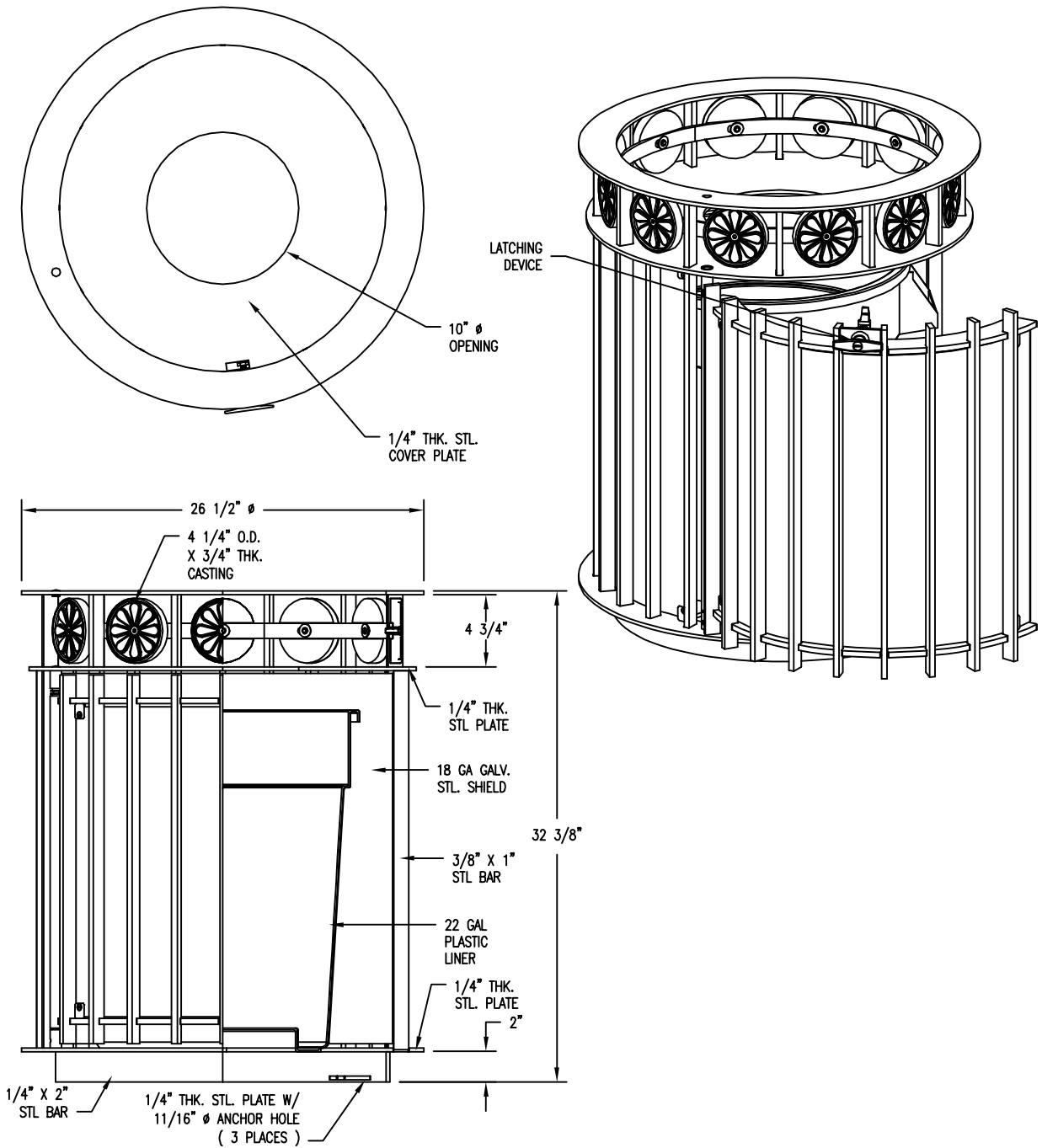

**NOTES:**

- 1.) ALL STL. MEMBERS COATED W/ ZINC RICH EPOXY THEN FINISHED W/ POLYESTER POWDER COATING.
- 2.) 1/2" X 3 3/4" EXPANSION ANCHOR BOLTS PROVIDED.
- 3.) SIDE OF RECEPTACLE HINGES OPEN FOR REMOVAL OF LINER.
- 4.) LATCH PROVIDED W/ KEY, USE OF KEY OPTIONAL.
- 5.) RECEPTACLE FULLY ASSEMBLED AT FACTORY.

**NOTES:**

- 1.) DURING ASSEMBLY PROCEDURE;  
DO NOT COMPLETELY TIGHTEN HARDWARE.
- 2.) THE ACTUAL PARTS WILL NOT BE NUMBERED.  
NUMBERS ONLY APPLY TO DRAWING.
- 3.) UPON COMPLETION OF ASSEMBLY SQUARE  
ALL COMPONENTS THEN TIGHTEN ALL HARDWARE.
- 4.) MOUNT AND ANCHOR AS SPECIFIED.

**TOOLS REQ'D**

- 3/4" WRENCH
- 1/2" MASONRY DRILL BIT  
DRILL

**PARTS LIST**

ITEM	QTY	PART NO	DESCRIPTION
1	1	0-102-20SH-FTO	20 GAL STL RECEPT ASMBLY FOR FLT TOP
2	1	49-22	22 GAL PL LINER W/HANDLE, BLK

**KITS PROVIDED**

ITEM	QTY	PART NO	DESCRIPTION
3	1	K-ANCO860-3	1/2" X 3 3/4" SS ANCHOR KIT (3PCS)

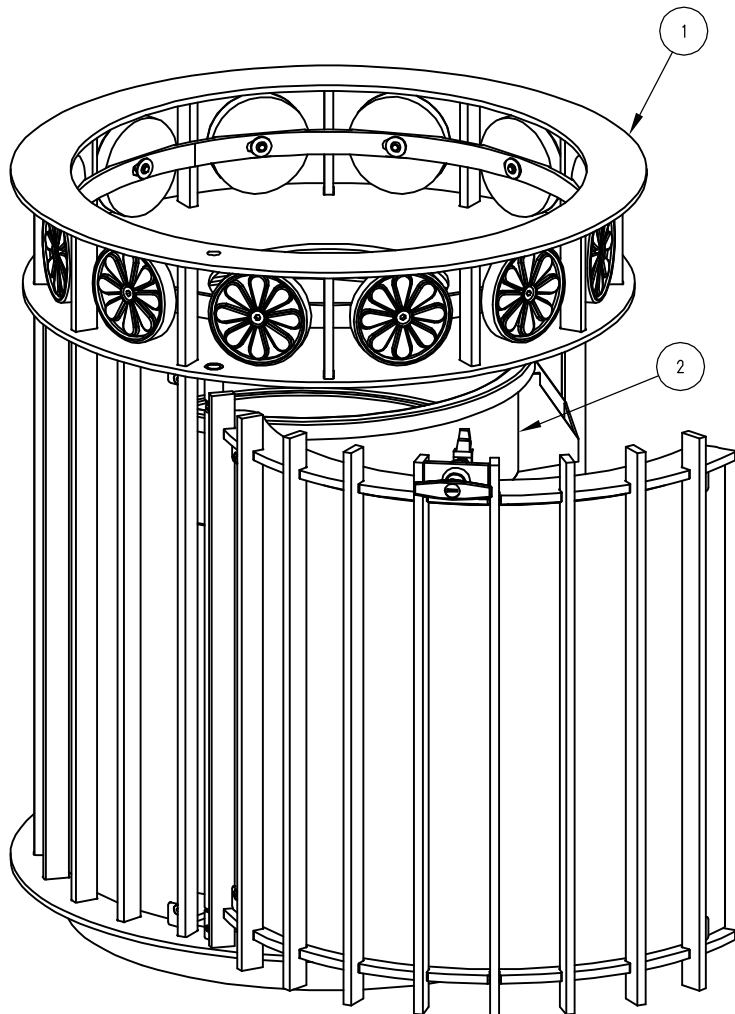

**STEFANI&Co.**

**QUOTE**

2900 Orchard Lake Road  
 Suite 5  
 Keego Harbor Michigan 48320  
 Phone 248-682-8818  
 www.stefaniandco.com

QUOTE #KH5-2-26  
 DATE: MAY 2, 2026

**TO: CITY OF KEEGO HARBOR**  
 Arch at Cass Lake rd.  
 Next to Margret's

**FRAN LEAF ARCHWAY**  
 2026

**COMMENTS OR SPECIAL INSTRUCTIONS: THE ARCH IS TO BE LOCATED 18' OFF OF CASS LAKE RD. ALL ASPECTS OF INSTALL INCLUDED.**

**THIS QUOTE IS GOOD FOR 30 DAYS**

SALESPERSON	QUOTE NUMBER	REQUISITIONER	SHIPPED VIA	F.O.B. POINT	TERMS
Jesse	KH5-2-26				

QUANTITY	DESCRIPTION	UNIT PRICE	TOTAL
1	Archway – Powder Coated cylinder steel posts (Color TBD) with limestone caps at each base. (8) ¾” round powder coated steel arches over the top to mechanically connect. (2) Custom glass glowing accent rings detail at pillar top (Solar). Includes (3) graphic design elements (fish, gull, sailboat, etc. TBD) waterjet aluminum and powder coated with mechanical connection. Included is the generic graphic Keego Harbor sign (TBD design) to hang below arch, to be waterjet, powder coated aluminum, mechanically attached. To sit upon two 12” round x 50” deep poured concrete pillars with adjustable “J” bolts foundations. (2) Ground lights to cast light on arch from both sides included (Solar).	\$20,350	\$20,350
	Includes installation.		
	50% deposit required to start construction.		
SUBTOTAL			\$20,350
PLUS ANY APPLICABLE SALES TAX			
TOTAL QUOTE			\$20,350

Make all checks payable to Stefani&Co.  
 If you have any questions concerning this quote, contact Cary Stefani

**THANK YOU FOR YOUR BUSINESS!**

City of Keego Harbor

Following our previous discussions regarding the site enhancements, please find the formal proposal and itemized quote attached for the **Arch at Fran Leaf Park**.

To provide a clear vision of the project, I have also included renderings of the proposed design and material descriptions. We have carefully selected these elements to ensure the arch not only serves as a beautiful focal point for the park but also stands up to local weather conditions and high foot traffic.

**Project Overview:**

- **Design Specifications:** Detailed dimensions and aesthetic finishes as discussed.
- **Materials:** High-grade, durable materials curated for longevity. Steel, aluminum, Limestone.
- **Timeline:** Estimated start date and projected completion upon approval.

Could you please confirm receipt of these documents? Once you have had a moment to review the details, I would be happy to hop on a call or meet in person to address any questions or specific concerns you may have.

We are excited about the possibility of contributing to the beauty of Fran Leaf Park and look forward to hearing your thoughts.

Best regards,

**Jesse Stefani** [248-891-2767] [Stefani & Co.]



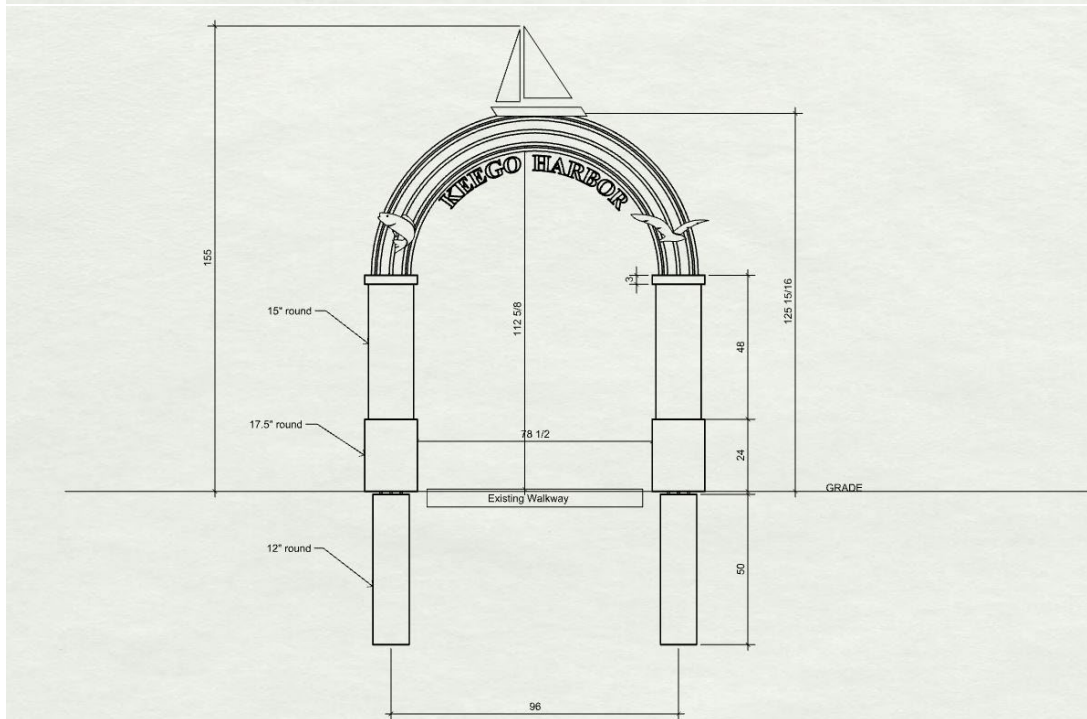
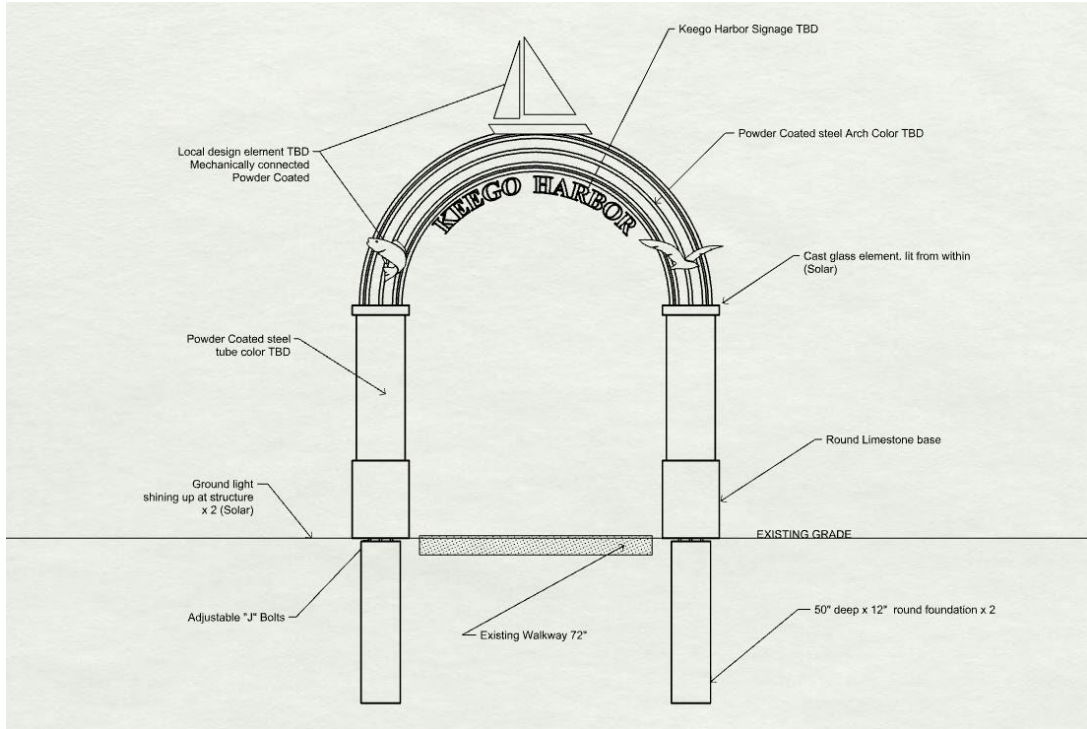

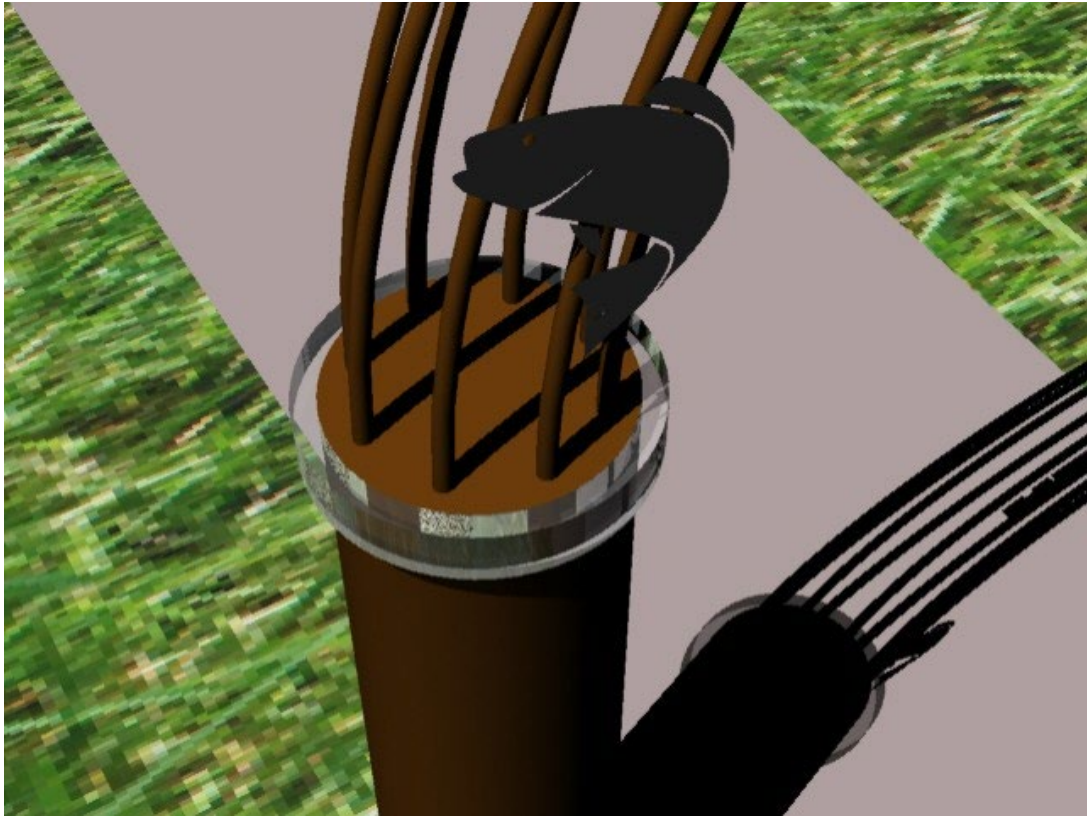

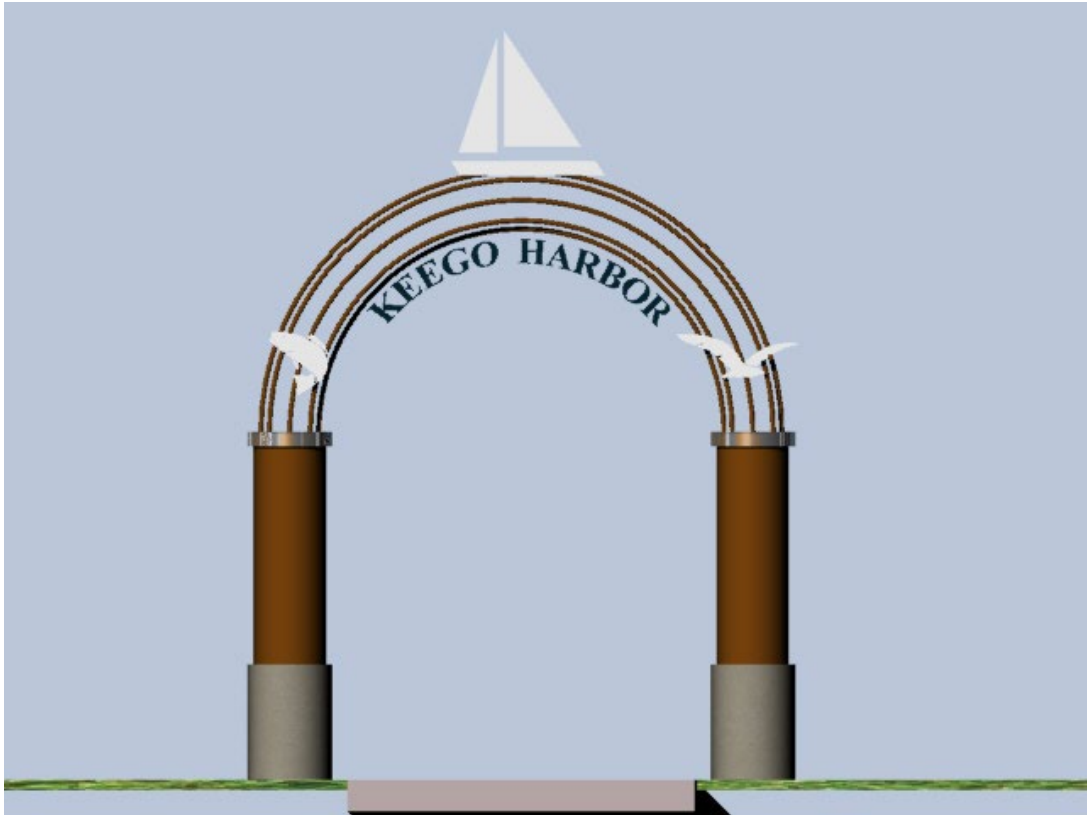
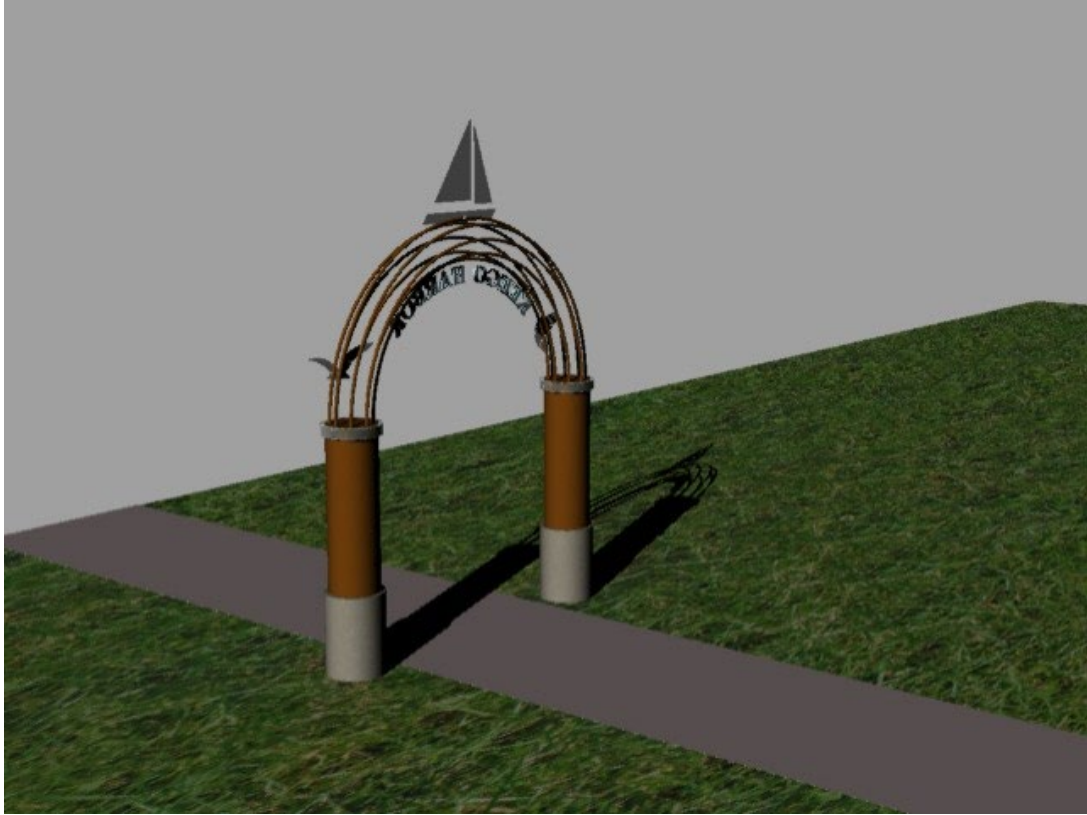

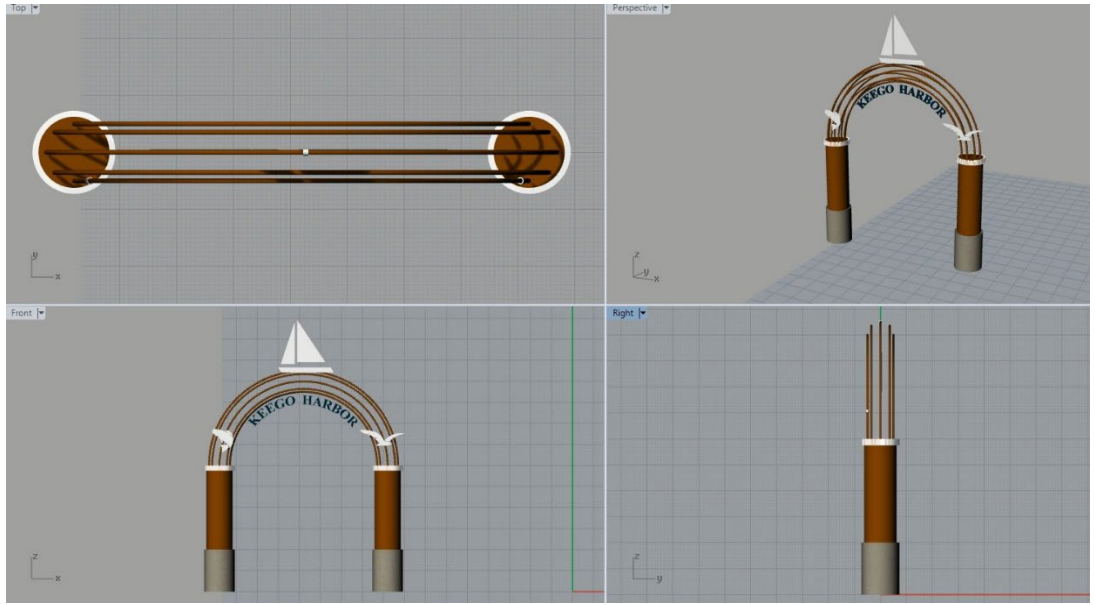



# METAL CITY F A B

## Quote No. 26-5188

Tammy Nebb  
City of Keego Harbor  
2025 Beechmont  
Keego Harbor MI 48320  
Phone: 248 682 1930  
Fax:  
Cell:  
Email: [manager@keegoharbor.org](mailto:manager@keegoharbor.org)

Date: Monday, May 11, 2026  
Estimator: Terry Dickinson  
Estimator Email: [terry.dickinson@metalcityfab.com](mailto:terry.dickinson@metalcityfab.com)  
Expiration Date: Thursday, May 21, 2026  
Terms: Net 30; 1.5% per month on past due invoices.

<b>Project Name:</b>		<b>DECORATIVE ARCHWAY PROJECT, FRAN LEAF PARK</b>		
<b>We Propose to furnish all labor and material necessary to perform the following work:</b>				
QTY	UNIT	Description	Unit Price	Total
1	EACH	Furnish and install a 12" wide 8'-0"x 10'-0" aluminum arch with cutout nature themes on (2) vertical sides, with a standard color powder coat finish.		
		* Standard powder coat colors are Black, White, and Bronze. Other colors are available, but may be at an increased cost.		
<i>Due to the interruption in material distribution, and manufacturing supply chains, goods and services may be delayed without notice.</i>				
<i>Escalation clause to be included in contract verbiage, and the ability to bill for stored materials.</i>				
<i>All payments made to AFS using a credit card will incur a 3.5% processing fee.</i>				
<i>Unforeseen digging conditions will incur additional charges</i>				
<i>Retention excluded when invoicing for stored materials.</i>				
			<b>TOTAL.....</b>	<b>\$14,596.00</b>

**Terms and Conditions**

- All field employees are 10 hour OSHA trained and certified.
- All work shall be performed using Non-Union Labor.
- All work shall be performed using Non-Davis Bacon / Prevailing Wage Rates.
- Performance testing excluded
- Engineering calculations included.
- All posts shall be set in concrete footings.
- All posts shall be set in 16" x 42-48" deep concrete footings.
- All welds are NOMMA #3 standard.
- An approved shop drawing must be received prior to fabrication.
- Clean up of excavated dirt included.
- Bonds excluded.
- Local building permits excluded.
- Price excludes everything associated with traffic management.
- Due to the volatility in the construction materials market, our prices contained herein remain firm for a period of 10 days from our proposal date.

Thank you for the opportunity to earn your continued business and remain as your single source for all your custom fabrication needs. Please feel free to contact me with any questions or requests.

Sincerely,

Terry Dickinson